



# Thermal Mass Flowmeter

## ATF2000 Series

# Operation Manual



# Index

1. Introduction	3
2. Technical Parameters and Functions	3
3. Appearance and Dimensions	4
3.1 Appearance	4
3.2 Dimensions	6
4. Wiring and Installation	7
4.1 Wiring	7
4.2 The Wiring for Remote Type	7
4.3 Installation	8
4.3.1 The Installation of Plug-in Flowmeter	8
4.3.2 Drilling Hole	10
4.3.3 The Installation of Plug-in Flowmeter (Hot Tap Tape)	11
4.3.4 The Installation of Remote Plug-in Flowmeter	11
4.3.5 The Installation of Pipe Type Flowmeter	12
5. Debugging and Running	13
5.1 Keyboard & Display	13
5.2 Parameter Input	13
5.3 Display Interface	14
6. Operation	15
6.1 Flow Parameter Setting	17
6.2 Output Setting	18
6.3 Communication Setting	19
6.4 Pulse Parameter Setting	20
6.5 Alarm Parameter Setting	22
6.6 System Parameter Setting	23
6.7 Instrument Coefficient	24
6.8 View Log	25
7. Maintenance	26
8. Troubleshooting	26
9. Noun Interpretation	27
10. MODBUS Address	28

## 1. Introduction

ATF2000 Series thermal mass flow meter is designed on the basis of thermal dispersion. It adopts method of constant differential temperature to measuring gas flow. It has the advantages of small size, high digitization, easy installation and high accuracy.

The sensor consists of two platinum resistance temperature sensors. Using bridge circuit, one sensor is used as a temperature sensor to monitor the actual process values while the other is used as a heater which is maintained at a constant differential temperature above this by varying the power consumed by the sensor. It is possible to measure flow at high temperature and high pressure.

### ALIA ATF2000 thermal gas mass flowmeter has the following technical advantages:

- No need for temperature and pressure compensation. It can measure the mass flow rate or standard volume flow rate of gas conveniently and accurately.
- Large range ratio. Gases with flow rates up to 120 m/s and down to 0.1 m/s can be measured. It can be used for gas leak detection.
- Good anti-seismic performance and long service life. The sensor has no moving parts and pressure sensitive parts. The measurement accuracy will not be affected by vibration.
- Easy installation and maintenance. Non-stop production installation and maintenance is possible if site conditions permit.
- Digital design. The whole instrument adopts a digital circuit which realizes accurate measurement and easy maintenance.

## 2. Technical Parameters and Functions

		Insertion type	Pipe-type
Measuring Medium		Single component gas and multi-component gas	
Pipe Size		Circular pipe: DN80-7000 mm or square pipe	Circular pipe: DN10-1000 mm
Flow Rate		0.1-120 m/s	
Accuracy		+/-1%, of reading +/-0.5% FS	
Working temperature		Normal temperature type: -40-200 °C High temperature type: -40-350 °C	
Working Pressure		Max. pressure: 63 kg/cm <sup>2</sup> (Please specify for special case)	
Power Supply		DC24V and AC90-260V Power ≤10W	
Response Speed		1s	
Output Signal	Current Output	4-20 mA (photoelectric isolation, up to 800 load), 2-channel 4-20 mA photoelectric isolation (optional: 2-channel 4-20 mA).	
	Pulse Output	Cumulative pulse: Optical isolated OD output, max. current is 120 mA, optional, 0.1-5999.9 ms of Pulse width adjustable (0.1 ms of resolution), the Min. Pulse interval time is 0.1-5999.9 ms (0.1 ms of resolution), the flow corresponding to a single pulse is 0.001-59999. (Optional)	
	Communication Output	RS-485 (MODBUS-RTU) (photoelectric isolation)	
	Alarm Output	No.2 circuit alarm limit can be DC30V/5A or AC250V/5A, which can be programmable to be normally open or normally closed state, as well as other alarm modes, such as flow and temperature limit alarm (optional function).	
Pipe Material		Metal or non-metallic	
Display		16 * 2, English, flow rate, total flow, medium temperature, alarm status, total running time, current date and time.	
IP Grade		Transmitter: IP67 Sensor: IP68	
Explosion-proof		Exd II CT4	

### 3. Appearance and Dimensions

The thermal gas mass flow meter consists of a transmitter and a sensor. According to the working environment, it can be divided into general thermal gas mass flowmeter and explosion-proof thermal gas mass flowmeter. According to the structure, it can be divided into integral plug-in type, integral pipe type, remote plug-in type and remote pipe type.

Integral type: The transmitter and sensor are integrated.

Remote type: The transmitter and sensor are remote.

#### 3.1 Appearance

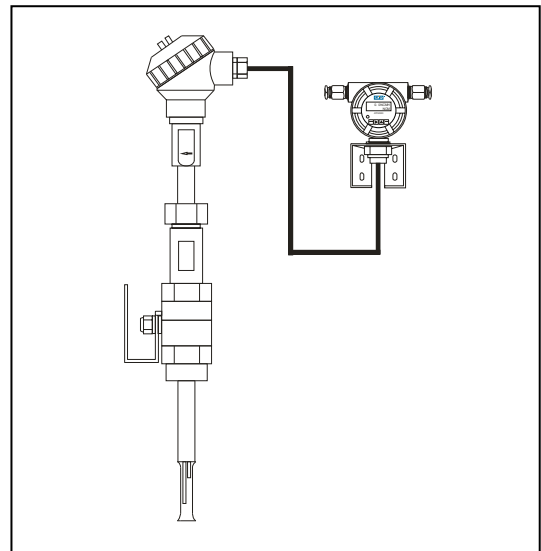
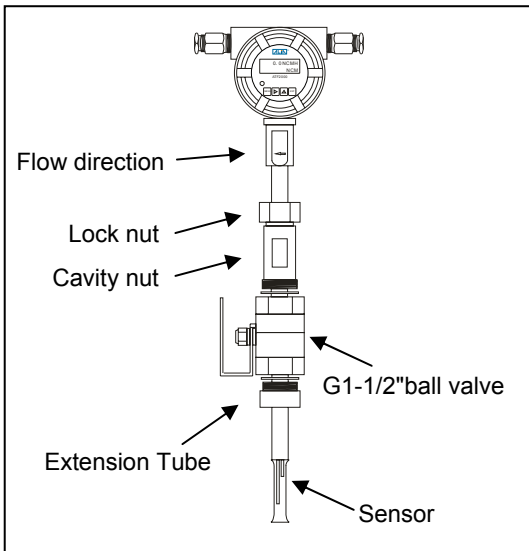
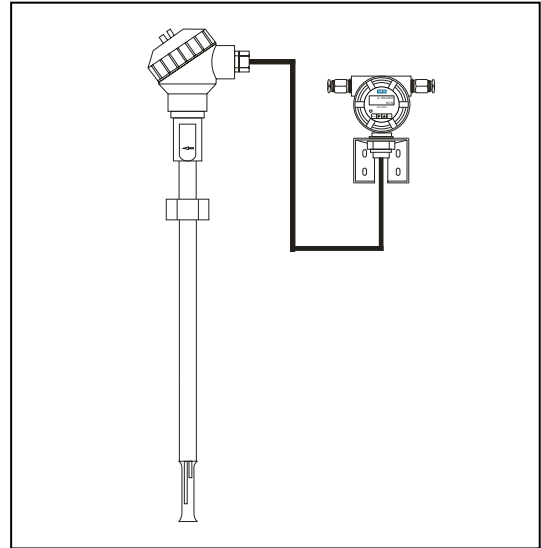
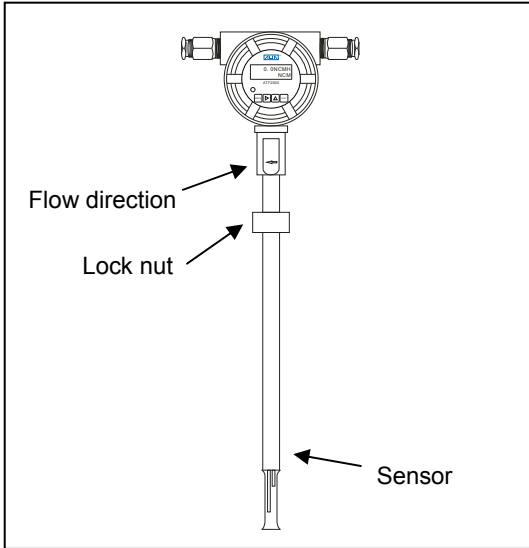

● On-line installation

● On-line installation

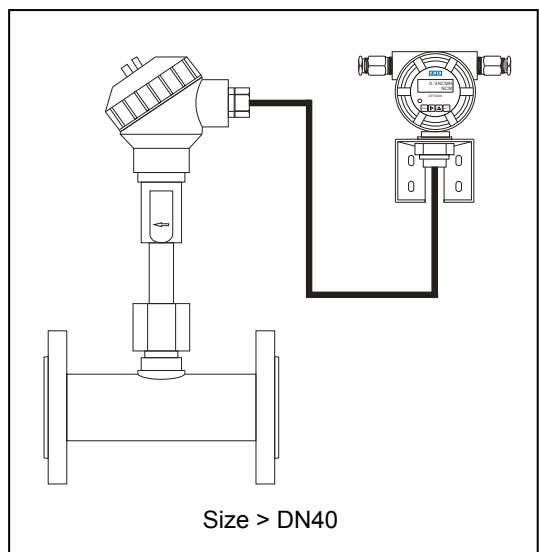
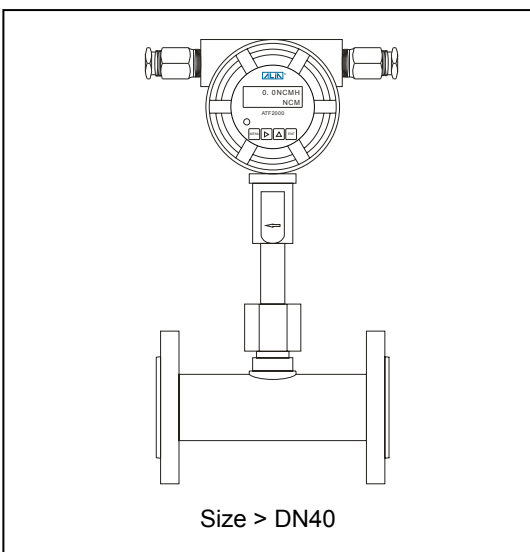
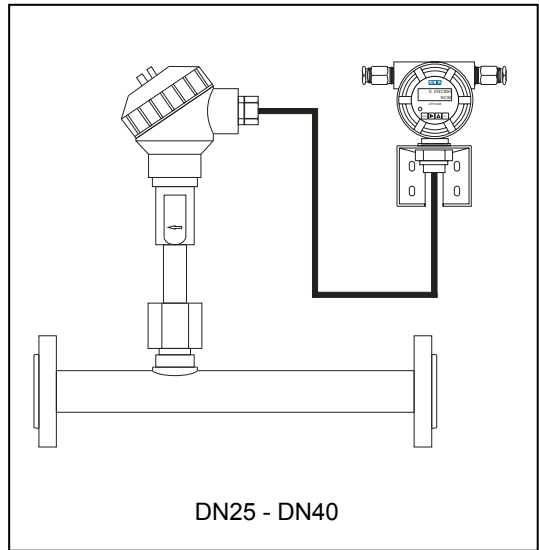
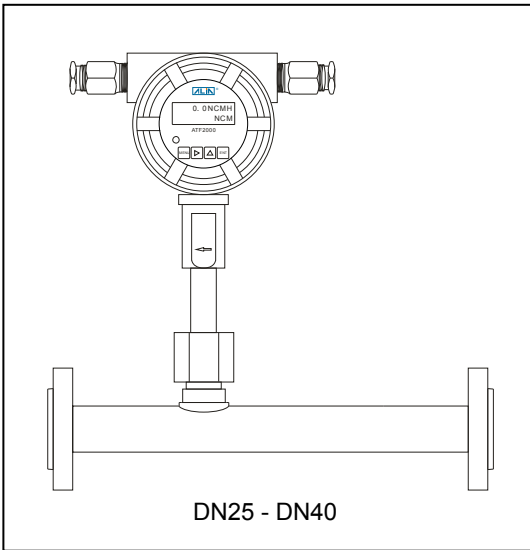
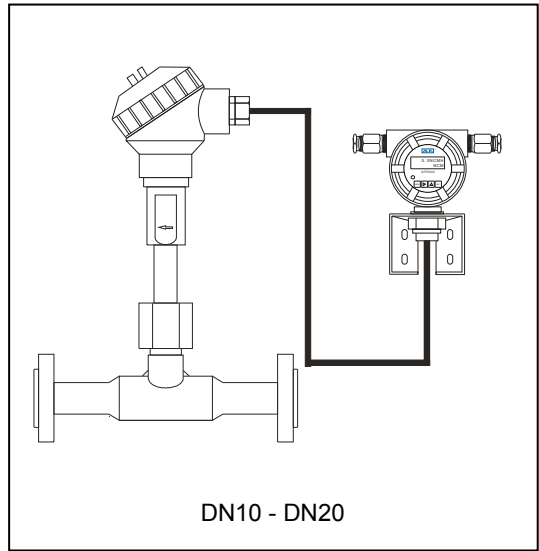
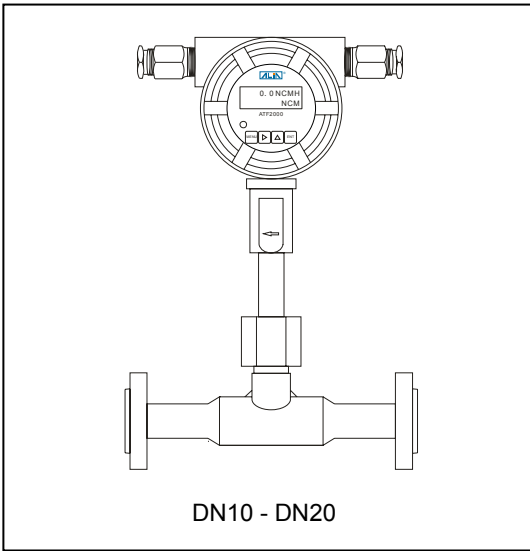

**3.2 Dimensions**

**Flange Type**

Unit: mm

Size		Flange Type		Size		Flange Type		Size		Flange Type	
mm	Inch	L	H	mm	Inch	L	H	mm	Inch	L	H
10	3/8"	280	313	80	3"	200	390	400	16"	480	748
15	1/2"	280	318	100	4"	220	409	450	18"	510	805
20	3/4"	280	323	125	5"	250	437	500	20"	550	868
25	1"	360	319	150	6"	300	467	600	24"	620	980
32	1-1/4"	360	334	200	8"	350	525	700	28"	690	1060
40	1-1/2"	360	343	250	10"	400	584	800	32"	750	1168
50	2"	150	355	300	12"	420	638	1000	40"	890	1383
65	2-1/2"	170	376	350	14"	440	694				

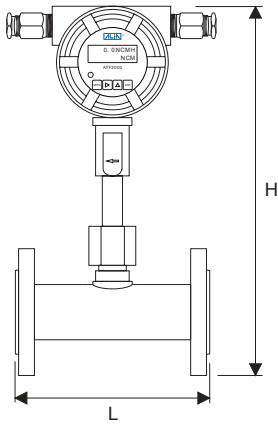

DN < 25

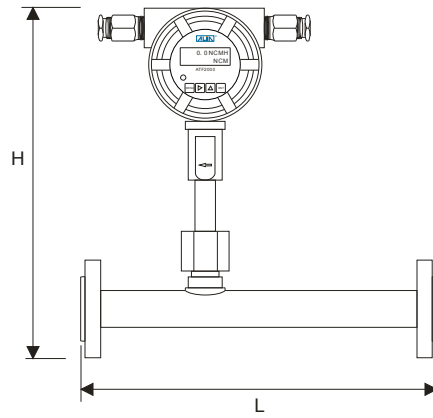

DN25 - DN40

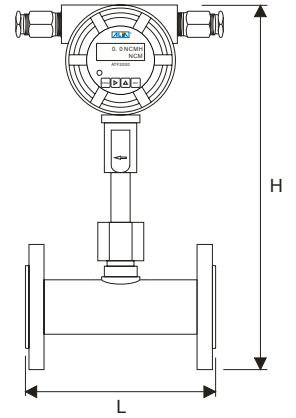

DN > 40

**Insertion Type**

L1 (mm)	L2 (mm)	Size
235	410	DN80-200 mm
385	560	DN80-500 mm
635	810	DN80-1000 mm
885	1060	DN80-1500 mm
1135	1310	DN80-2000 mm
Other	Other	>DN2000 mm

①	Nut	M33 * 2
②	Adapter	M33 * 2 / G1-1/2"
③	Ball Valve	G1-1/2"
④	Extension Tube	G1-1/2" / Welding

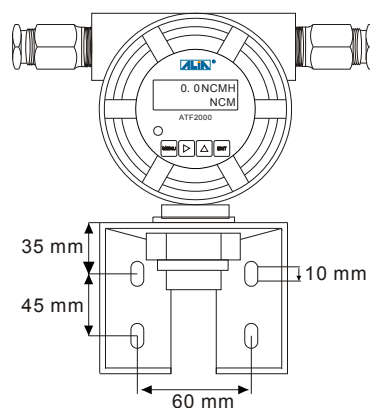
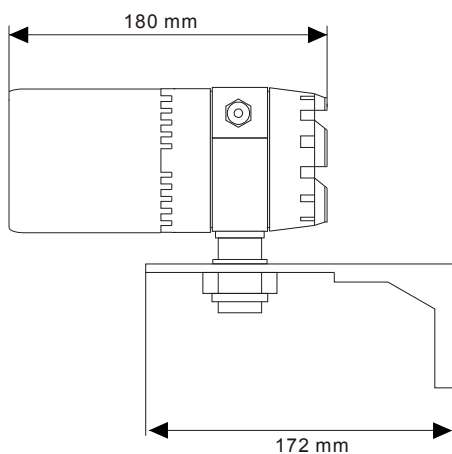
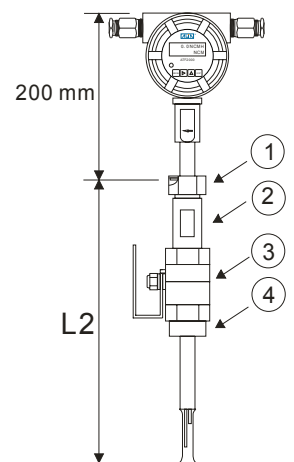
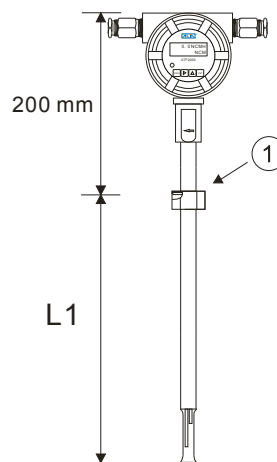

## 4. Wiring and Installation

### 4.1 Wiring

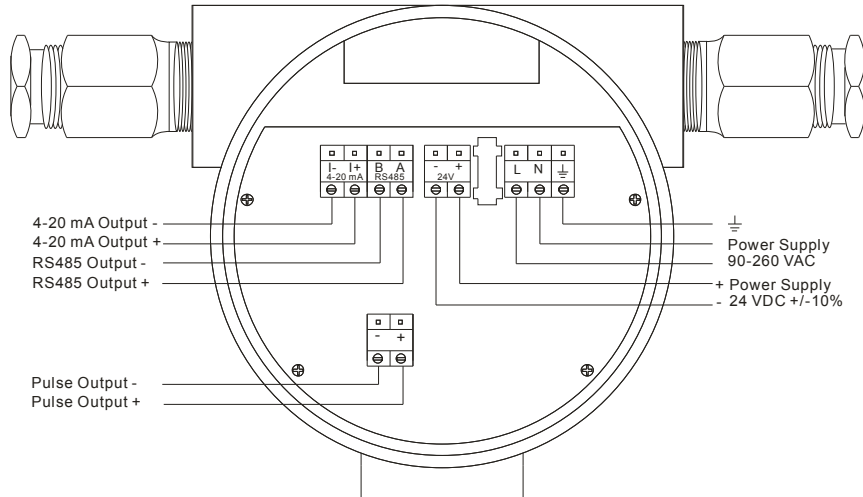

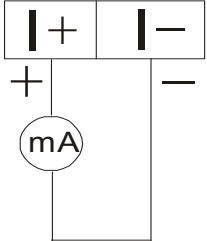
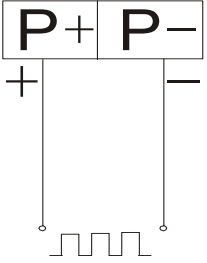
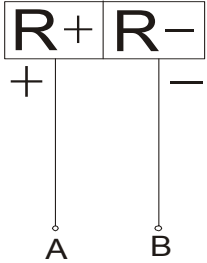
 <p>Max. Output Load: 800 <math>\Omega</math></p>	 <p>Max. Supply Voltage: 35 VDC Max. Current: 120 mA</p>	 <p>MODBUS Output</p>
<p>4-20 mA Output (Hart Protocol)</p>	<p>Passive Pulse Output</p>	<p>MODBUS Output</p>

### 4.2 The Wiring for Remote Type

H1		Blue
H2		Brown
H3		Green
L1		Grey
L2		White
		Black

The meaning of wiring label is as follows:  
 PT10: H1,H2  
 PT1000: L1, L2-  
 Temperature compensation: H3  
 Shielded wire: GND

### 4.3 Installation

The flowmeter can be installed on horizontal, vertical or inclined pipes, and at any angle in the circumferential direction of pipes, but it's necessary to consider the convenience of operation and maintenance.

For dirty or humid gases, it's recommended to install the flow meter horizontally (up) to reduce the possibility of contamination of the sensor. The installation position of the sensor should avoid the lowest part of the pipeline to prevent the water from accumulating in the pipeline and make the flowmeter unable to work properly.

#### Installation Position

- Upstream distance should be 10D while downstream 5D. If there is a gas rectifier on pipeline or the gas flow rate is less than 30 m/s, upstream distance can be 5D and downstream can be 3D.
- Explosion-proof areas are prohibited from fire. If the pipes are not weldable, special clamps can be used to fix the sensor on the pipe. Manual drilling tool is used in the explosion-proof area and electric drilling tool is used in the safe area.
- The arrow direction "→" on the sensor housing should be consistent with the flow direction of gas. The insertion direction of the sensor should be perpendicular to the flow direction of gas.
- Do not install the flowmeter in places with strong vibration.
- Do not share power with equipment that contaminates the power supply such as inverters, welders. If necessary, install a power conditioner for the transmitter.

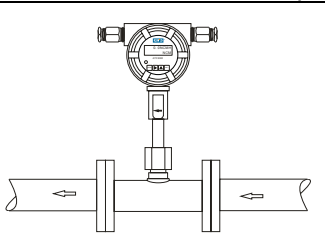
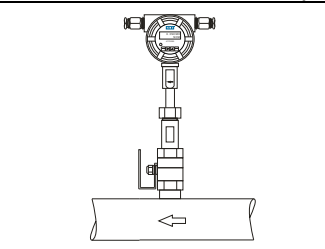
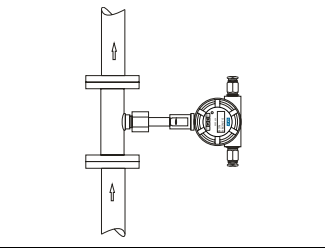
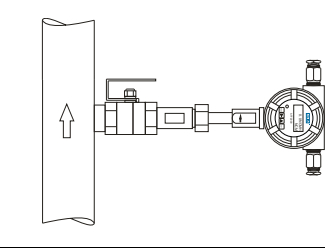
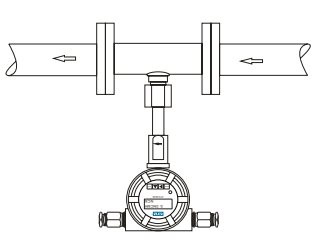
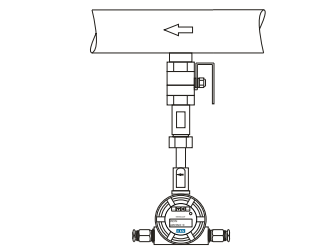
Pipe-Type		Plug-in Type	
Horizontal Pipeline Installation (Up)		Horizontal Pipeline Installation (Up)	
	√ Recommended		√ Recommended
	√ Recommended		√ Recommended
	× Not Recommended		× Not Recommended

#### 4.3.1 The Installation of Plug-in Flowmeter

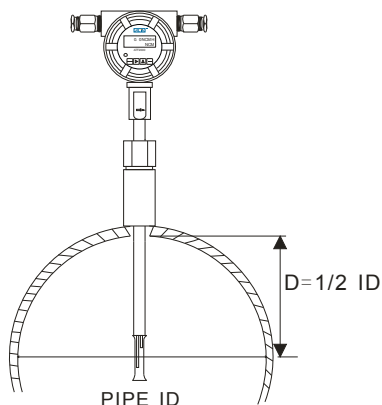

Insertion Type

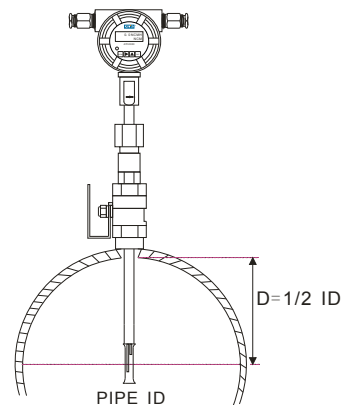

Hot Tap Type



The connection of extension tube can be divided into welding type and clamp type according to different pipe materials (weldable and non-weldable). If the pipe material is cast iron or non-metallic, the extension tube can not be mounted by welding. In this case, the special fixture provided by the manufacturer (the extension tube is welded to the fixture) should be used. The size of the fixture depends on the outer diameter of the pipe.

• Welding type

1. Locate the apex of the pipe and adjust the threaded extension tube (G1-1/2" threaded extension tube or M33 \* 2 threaded extension tube) to the apex to make the axis of the threaded hole passes through the apex and is perpendicular to the axis of the pipe.
2. Weld the threaded extension tube to the pipe by welding machine. It must be welded firmly, and no welding defects such as slag inclusions and air holes are allowed.

**Note: If air cutting is used, the base should be welded after tapping.**

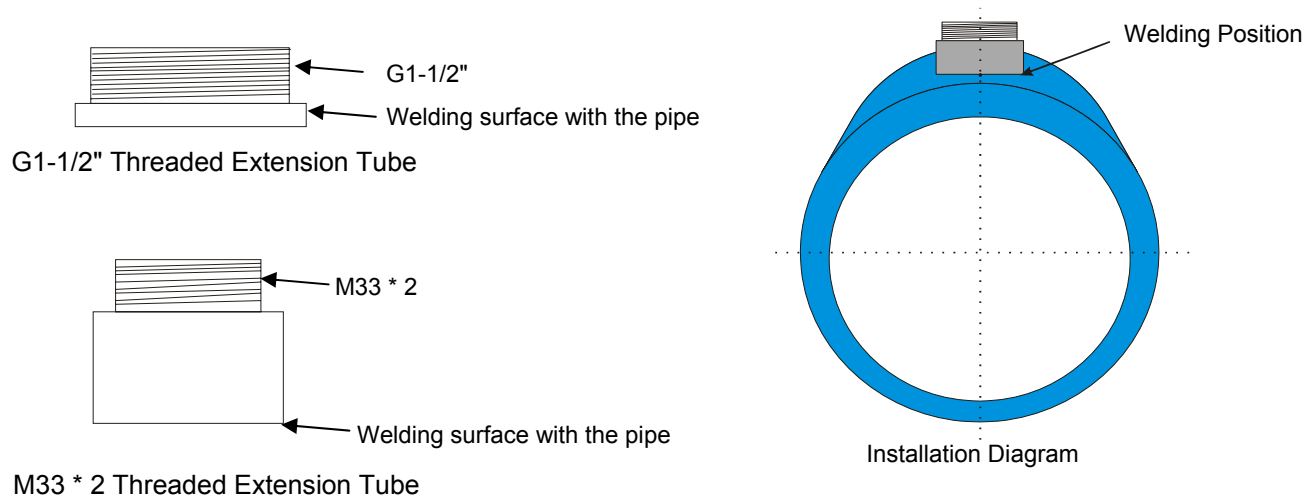

• Strap-on type (Saddle fitting (carbon steel))

1. Place the fixture on the pipe and locate the apex of the pipe and adjust the threaded base to the apex to make the axis of the threaded hole passes through the apex and is perpendicular to the axis of the pipe.
2. Tighten the two nuts on the clamp to ensure that they will not loosen after locking.

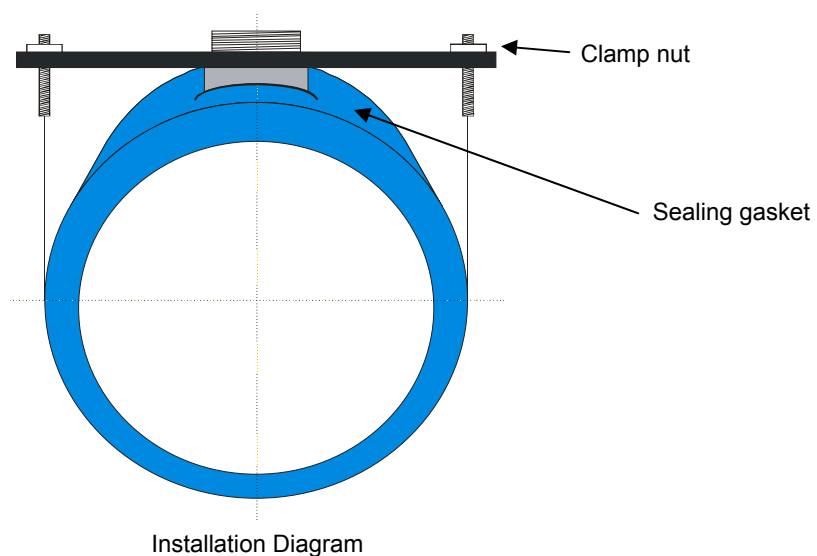

Check the installation environment carefully before drilling hole to ensure safe operation. After the hole is drilled, close the valve in time to avoid air leakage.

- Stop production

When the production is stopped, there are many ways to drill holes. The diameter of the hole should not be less than 22 mm, and the axis of the hole should be concentric with the axis of the hole of the extension tube. After drilling the hole, tighten the stainless steel valve to the extension tube. (G1-1/2" / M33 \* 2 threaded extension tube is sealed with gasket)

- None-stop production

If on-line drilling is needed, the special drill tool of our company can be used to achieve on-line installation. The special drill tools include manual drill tool and electric drill tool. Manual drill tool are required for use in an explosion-proof environment.

The following is a brief description of how to use the electric drill tool.

1. Tighten the stainless steel valve ① to the extension tube and open it.
2. Hold the cavity nut ③ and move the rod body ② upward so that the drill bit ④ can return to the cavity nut ③.
3. Connect cavity nut ③ with stainless steel valve ① and pay attention to tightening and sealing the thread.
4. Push the rod body ② down to the pipe wall and connect the electric drill ⑤ to the top of the rod to start drilling.
5. After drilling, remove the electric drill ⑤ and then adjust the rod upward until the rod remote from the stainless steel valve ①. Close the stainless steel valve ① and turn the cavity nut to remote it from the valve. The drilling is completed.

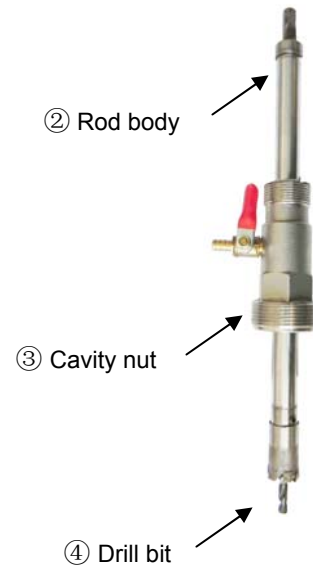
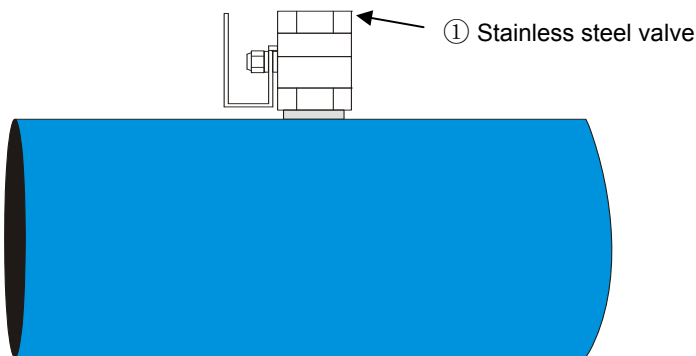

⑤ Electric drill

### 4.3.3 The Installation of Plug-in Flowmeter (Hot Tap Tape)

1. Loosen the lock nut ④ on the sensor rod to enable the cavity nut to slide along the sensor rod ③ to the sensor sheath ⑨ so that the sensor sheath ⑨ can fully retract into the cavity nut ⑥.
2. Fasten the cavity nut ⑥ to the ball valve. (The G1-1/2" threaded base is sealed with a gasket)
3. Open the stainless steel ball valve and insert the sensor rod into the pipe.
4. Insert the sensor rod into the pipe until it reaches the limit boss. Turn the sensor rod to make the direction of the arrow on the flowmeter is consistent with the flow of the medium, and then lock the lock nut ④.

**Note: Please insert the sensor sheath ⑨ into the center of the pipe during use.**

To ensure that the sensor sheath ⑨ is inserted into the center of the pipe, please measure the total length L of the sensor rod. After insertion, the length of the rod outside the pipe should be

$$l = L - 1 / 2DN - \text{wall thickness.}$$

**So it's required to design the length of the extension tube before the installation.**

### 4.3.4 The Installation of Remote Plug-in Flowmeter

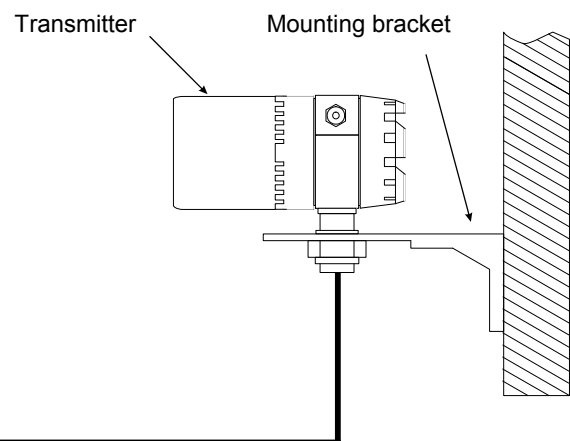
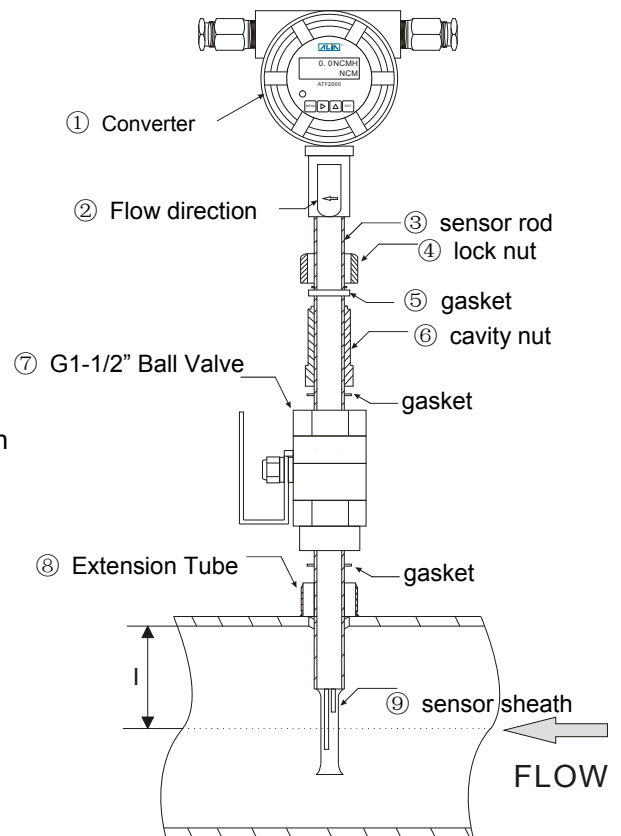
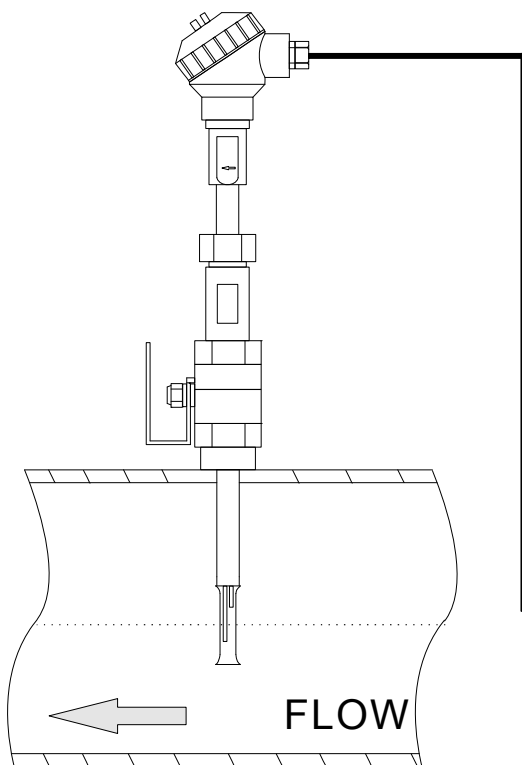

**4.3.5 The Installation of Pipe Type Flowmeter**

The production should be stopped during installation and the connection of the pipeline (flange or threaded) should be confirmed.

The sensor has been assembled on the special pipe before leaving factory. Users only need to assemble the pipe to the site, which is simpler than the installation of the plug-in flowmeter. During installation, please cut the pipe and install the mating flange according to the length of the sensor. Lock the flange hole by bolts and install the pipe type flowmeter on the pipe. Please note that the flow of the medium should be consistent with the direction of the arrow on the flowmeter.

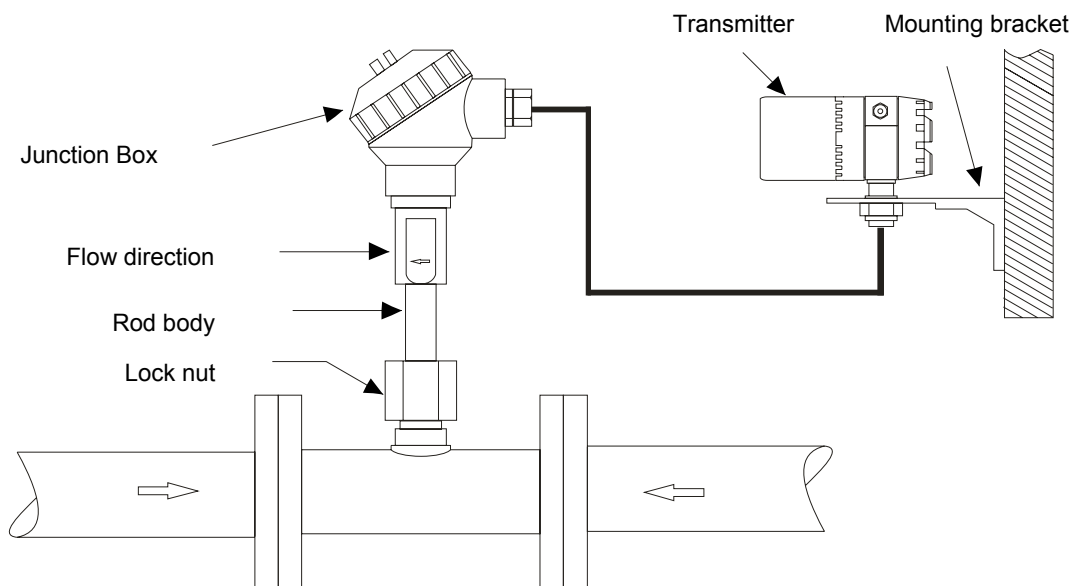
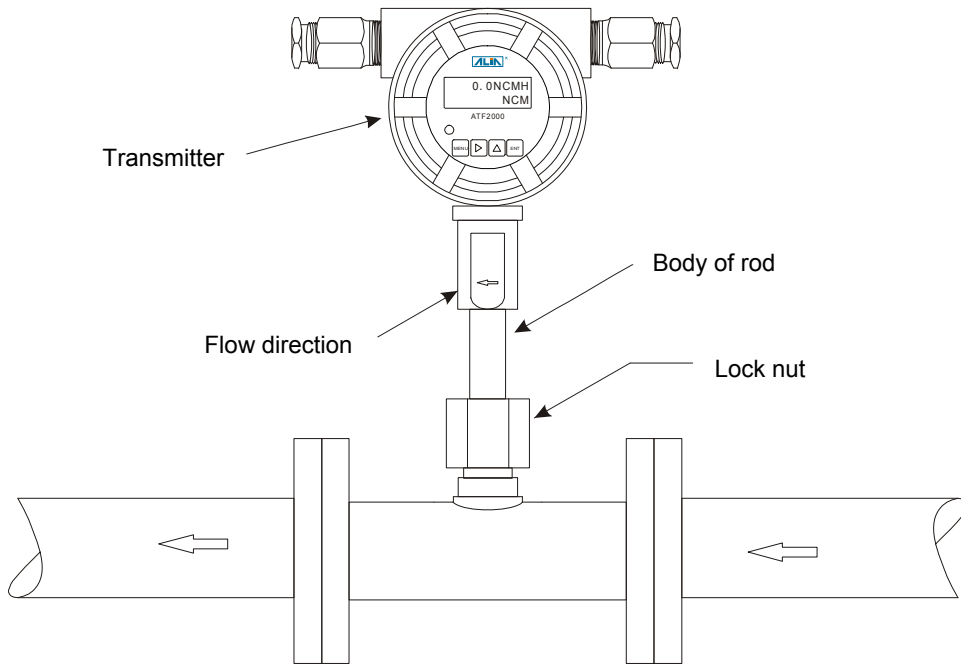





## 5. Debugging and Running

### 5.1 Keyboard & Display

#### • Keyboard

The thermal mass flow meter has 4 keys and it shows by 2 \* 16 characters. The flow rate and totalizer, medium temperature and total time, current date and time, and instrument status data can be displayed in four screens.

Key name	Key icon	Function under normal display	Function user parameter setting
Set key		Enter parameter setting	1. Cancel the current input value 2. Return to previous menu
Move key		None	Move cursor
Up key		Cycle display the measurement menu	Modify value
Enter key		Confirm	Save and exit

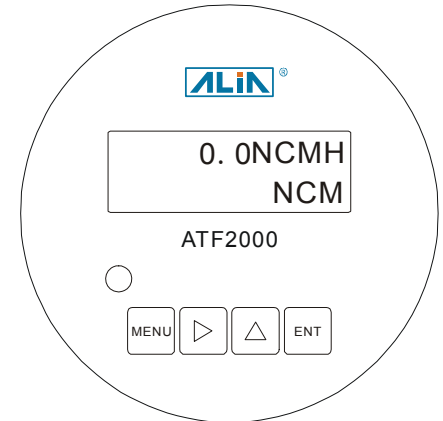

#### • IR Remote control (Optional)

The intrinsically safe remote control (ExibIICT6) is an infrared remote control with 16 keys. It adopts the design of sending signal only (no infrared signal received). The remote control is mainly used to set the parameters of the transmitter if it's not allowed to power on the transmitter and open its cover on site for parameter setting. Align the infrared emitter of the remote control with the receiver on the meter, and set the meter's parameters by keeping the distance less than three meters without blocking.



"PRINT": Meaningless

">": Cursor movement key, which is used to move the cursor when setting parameter.

"^": Change the value. The measurement menu is displayed cyclically during measurement.

"MENU": Switch between the interface of parameter setting and measurement. When setting the parameter, if the cursor is at the position where the value is entered, press this button to cancel the current input value.

"ENT": Confirm the entered data.

"0-9" and ".": It's used to enter values and decimal points.

### 5.2 Parameter Input

When the instrument is powered on, press MENU to enter parameter setting. The screen will show two lines, the upper right corner displays the menu number. The "ENT" key is used to confirm the modified parameters; the ">" key is used to move the cursor or turn the page; the cursor is the underline below the value. If input value in a certain position, press the "^" key to increase or decrease (decimal point and 0-9) the value.

In the parameter input interface, if the cursor is at the menu number, press the "MENU" key to switch the interface to measurement interface.

In the measurement interface, press "<" to show the measurement menu in a loop. If the menu where the parameter is located has a "→" prompt, it indicates that the length of the current parameter is beyond the display, press ">" to turn to the next page.

Each parameter is explained in detail below. The meter has two-level menus, there are five main menus and each main menu contains several sub-menus.

On the left of each "Parameter Description" is a simulation diagram of the LCD. The two digits in the upper right corner of the display represent the menu number. After setting some menu items and pressing the ENT key, users need to press the MENU key twice to restart the meter for the setting to take effect or wait until the menu items are all set and then to restart the meter.

#### Note:

1. Please do not interchange circuit boards between meters, otherwise it will affect the normal operation of meter. If necessary, please contact ALIA engineers.
2. When setting parameters, please ensure that the power supply of the instrument is normal. If the power is suddenly turned off, the parameters may be lost. After power on, it's necessary to confirm again whether the parameters are set successfully.

**5.3 Display Interface**

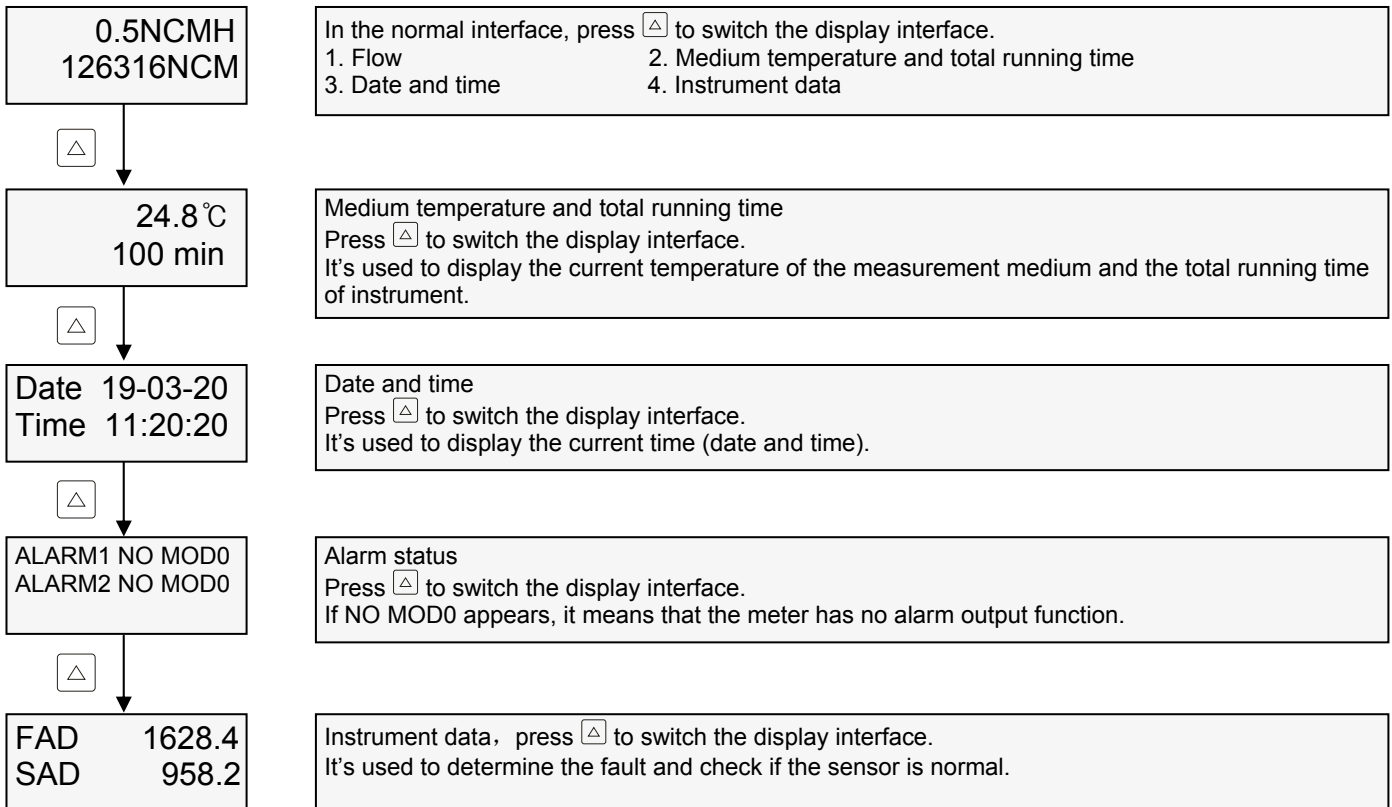

**6. Operation**

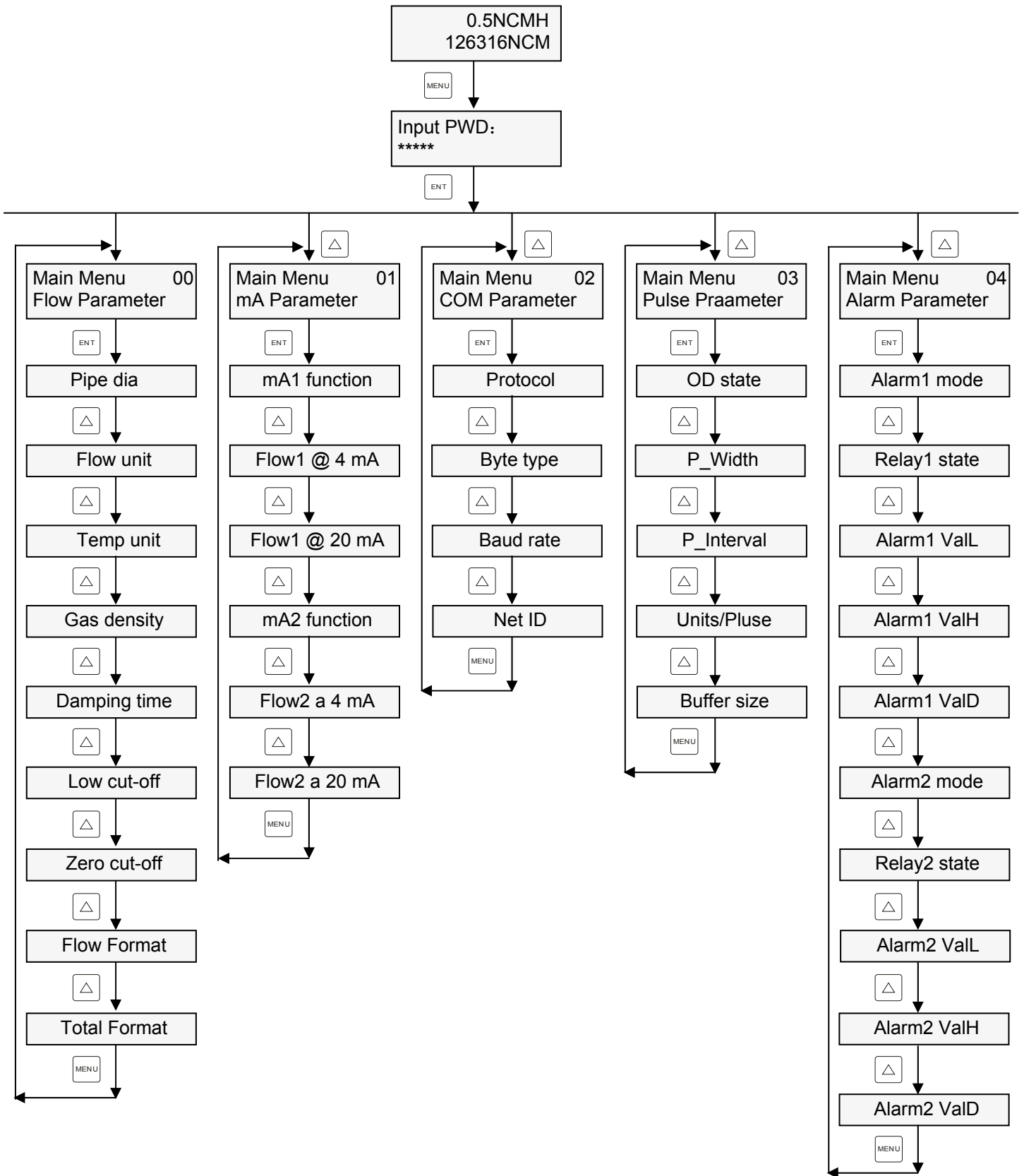

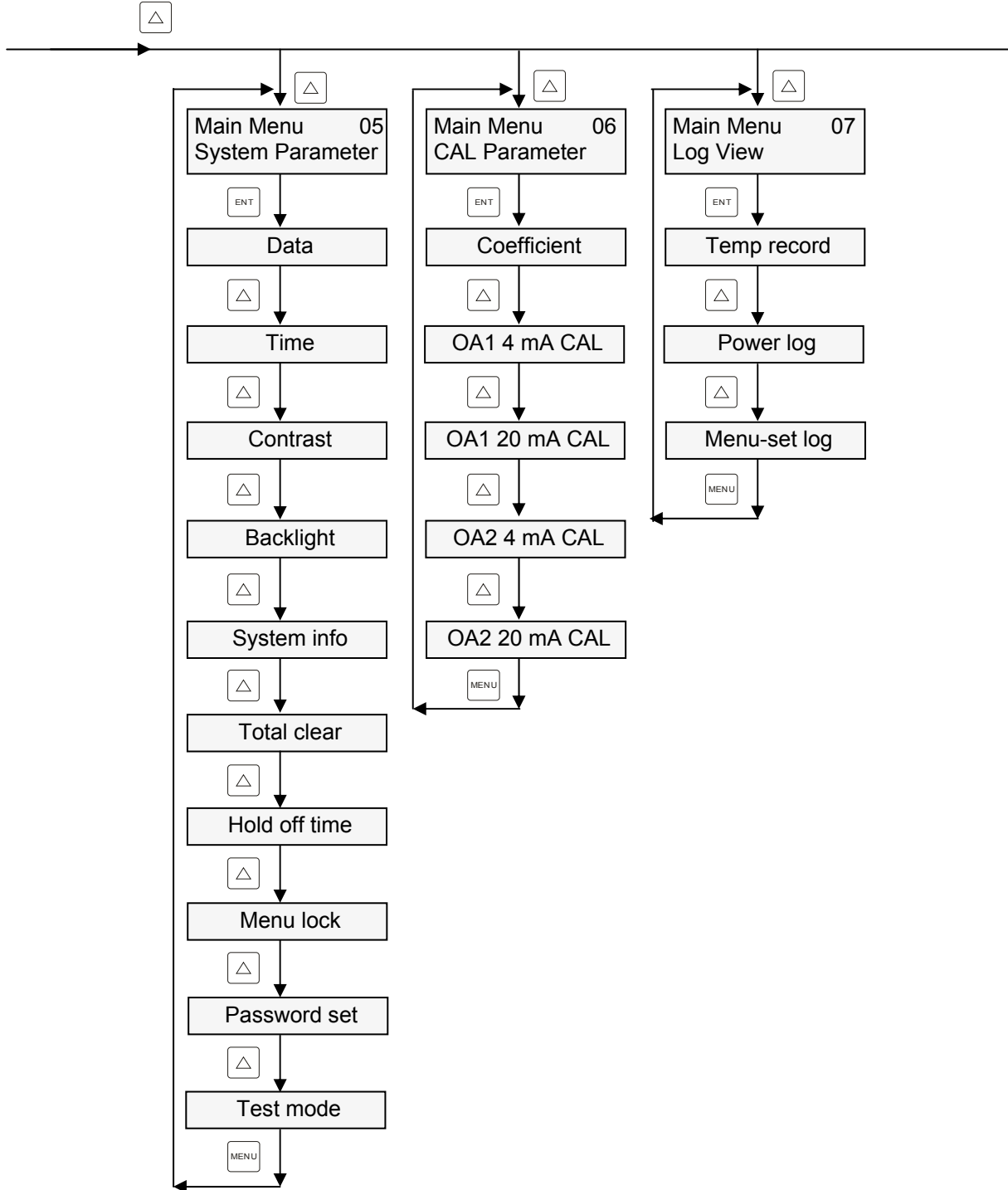



### 6.1 Flow Parameter Setting

0.5NCHM  
126316NCHM

In display interface, press to switch to flow parameter setting.

↓  
Main menu 00  
Flow parameter

Press to choose flow interface, press to enter flow setting interface.

↓  
Pipe dia (00)  
50.00 mm

Press to choose size setting press to enter.  
Press to move cursor and press to change size. Please enter the actual size.

↓  
Flow unit (01)  
0 <NCHM>

Press to choose flow unit, press to enter.  
Press to change flow unit. 0.NCHM 1.KGH 2.NLPM 3.KGM 4.SCFH 5.PPH 6.SCFM 7.PPM  
Press to confirm the modification. **Note: Press ENT to confirm and press MENU twice to restart the instrument for the setting to take effect.**

↓  
Temp unit (02)  
0 <°C>

Press to choose Temp unit, press to enter.  
Press to change Temp unit. 0.°C 1.°F  
Press to confirm the modification.

↓  
Gas density (03)  
1.203 kg/m<sup>3</sup>

Press to choose density, press to enter.  
Press to move cursor. Press to confirm the modification. It's used for the conversion between the volume under standard condition and mass.

↓  
Damping time (04)  
05s (00-32s)

Press to choose damping and press to enter.  
Press to move cursor. Press to change damping and press to confirm the modification.  
Damping can be set here if the flow rate fluctuates greatly. The larger the damping is, the slower the flow rate changes.

↓  
Low cut-off (05)  
0.0000000 NCHM

Press to choose low cut-off and press to enter.  
Press to move cursor and press to change low cut-off value.  
Formula: cross-sectional area \* velocity = low cut-off value  
It will display 0 after cutting off the small value. Press to confirm the modification.

↓  
Zero cut-off (06)  
0.0000000 NCHM

Press to choose zero cut-off and press to enter.  
Press to move cursor and press to change zero cut-off value. Assume that the instrument displays a zero value of 0.1NCHM, you can set 0.2NCHM here, and the instrument will display 0 NCHM.  
Press to confirm the modification.

↓  
Flow format (07)  
1 <X.X>

Press to choose the decimal place setting for flow rate and press to enter.  
Press to change the decimal point. 0.Integer 1. Keep 1 decimal place 2. Keep 2 decimal places  
3. Keep 3 decimal places  
Press to confirm the modification.

↓  
Total format (08)  
0 <X>

Press to choose the decimal place setting for totalizer and press to enter.  
Press to change the decimal point. 0. Integer 1. Keep 1 decimal place 2. Keep 2 decimal places  
3. Keep 3 decimal places  
Press to confirm the modification.

**6.2 Output Setting**

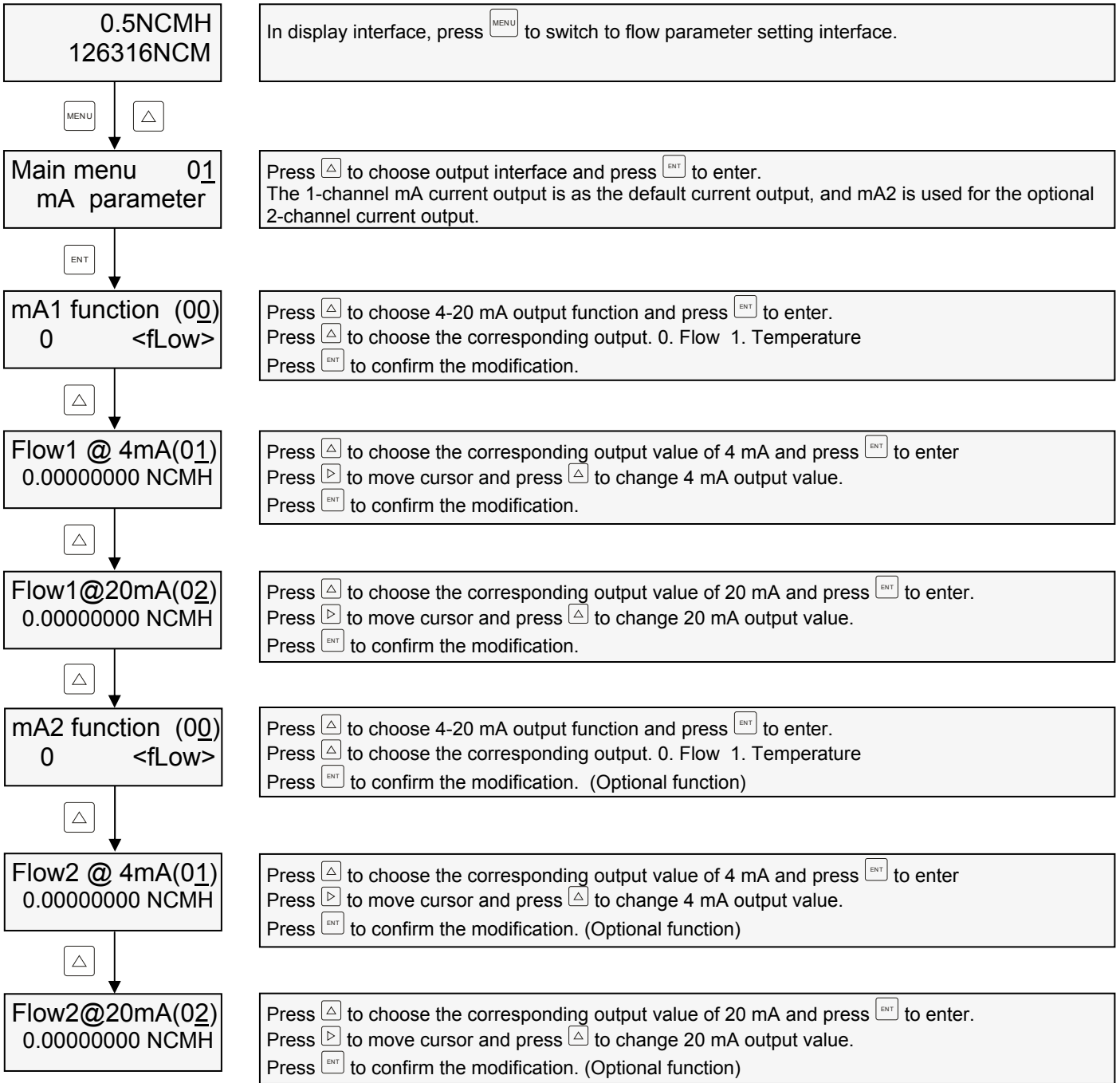

**Note: Only 4-20 mA loop of 1-channel can be selected in HART function.**

**6.3 Communication Setting**

0.5NCMH  
126316NCM



In display interface, press to switch to flow parameter setting interface.

Main menu 02  
COM Parameter



Press to choose Communication interface and press to enter.

Protocol (00)  
1 <Modbus-RTU>



Press to choose protocol and press to enter.  
Press to change communication output. 0. MProtocol (custom protocol) 1. MODBUS-RTU  
**Note: Press ENT to confirm and press MENU twice to restart the instrument for the setting to take effect.**

Byte (01)  
0 <1,8,N,1>



Byte format  
Press to enter.  
Option: 0-5  
0-0 parity bit, 1 stop bit 1-odd parity, 1 stop bit 2-even parity, 1 stop bit  
3-0 parity bit, 2 stop bits 4-odd parity, 2 stop bits 5-even parity, 2 stop bits  
**Note: Press ENT to confirm and press MENU twice to restart the instrument for the setting to take effect.**

Baud rate (02)  
4 <9600 bps>



Press to choose baud rate and press to enter.  
Option: 0-3 0. 1200 1. 2400 2. 4800 3. 9600  
**Note: Press ENT to confirm and press MENU twice to restart the instrument for the setting to take effect.**

Net ID (03)  
001 (1-247)

Press to choose Net ID and press to enter.  
Option: 001-247  
**Note: Press ENT to confirm and press MENU twice to restart the instrument for the setting to take effect.**

## 6.4 Pulse Parameter Setting

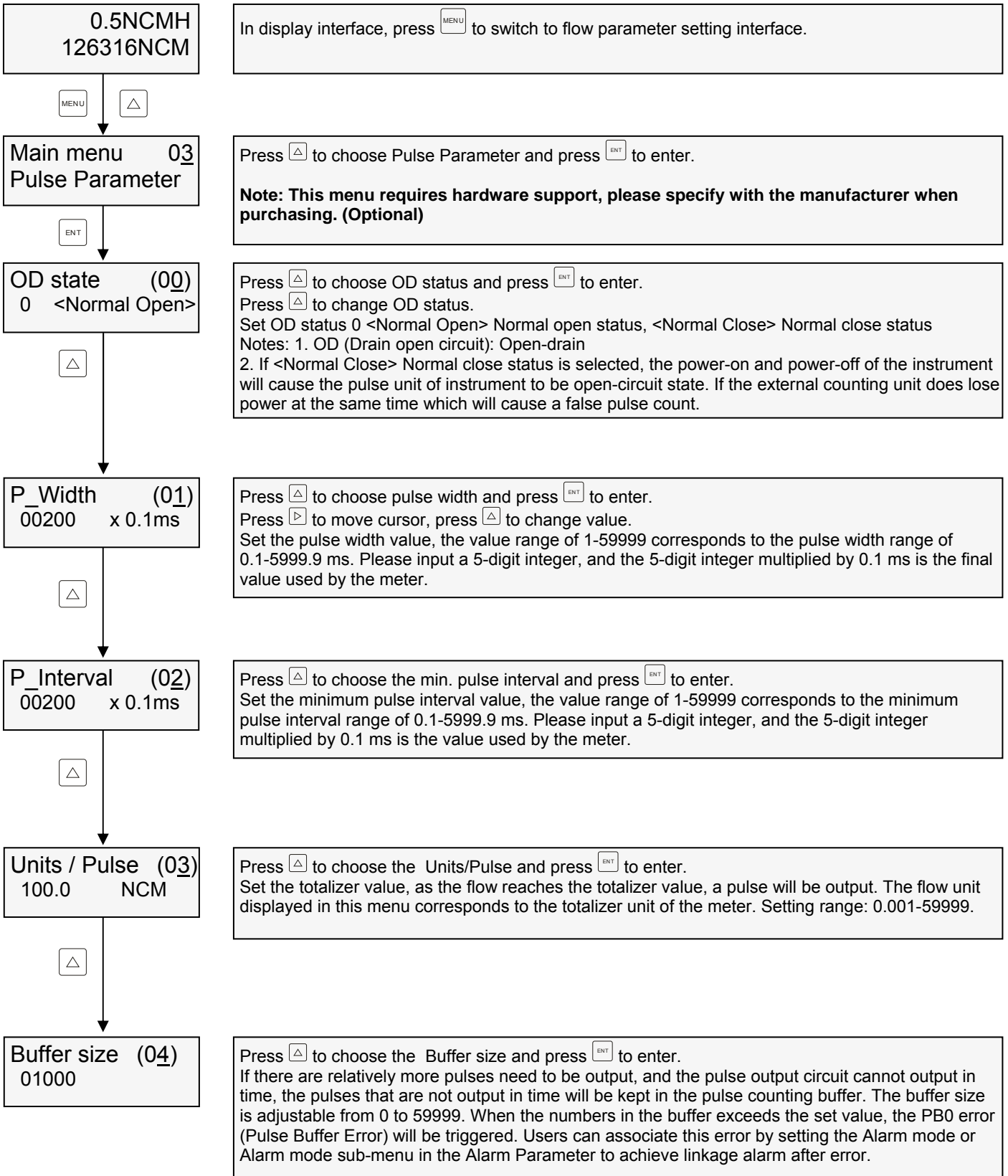

The time unit s of "P\_Width" and "P\_Interval" are ms, and the setting range is from 0.1 to 5999.9 ms.

Figure 1 shows the scope controlled by the parameter in the "normally open" mode, and Figure 2 shows the scope controlled by the parameter in the "normally closed" mode.

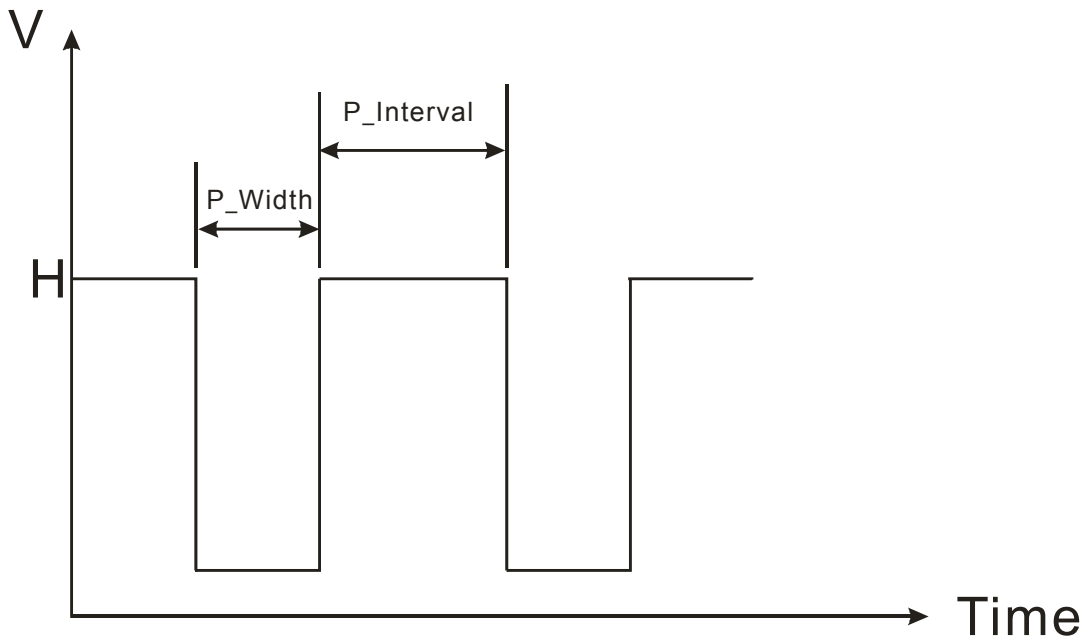

Figure 1

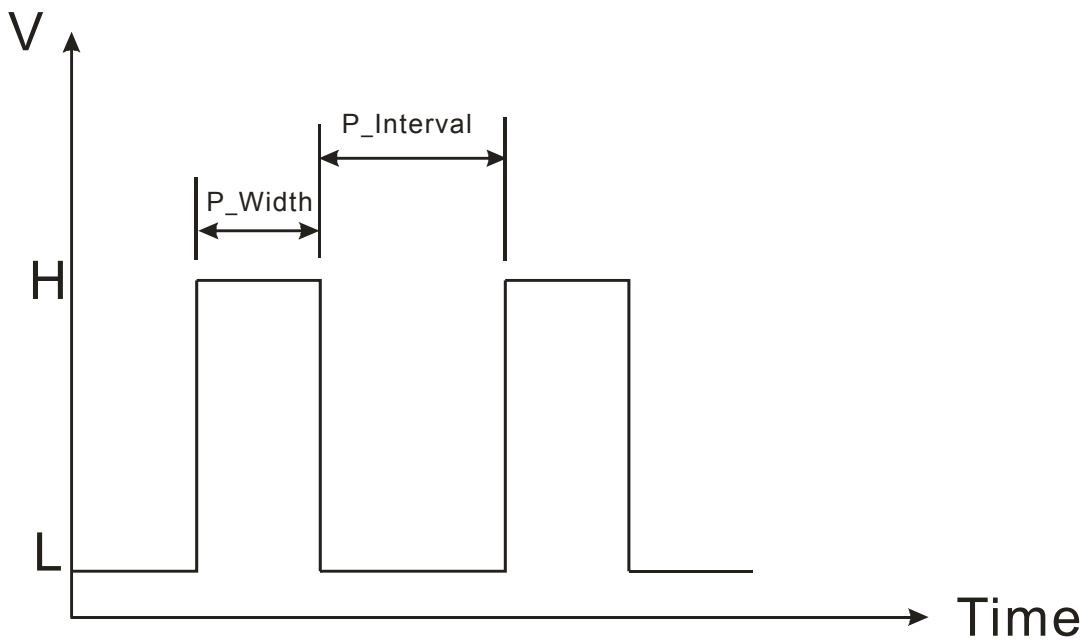
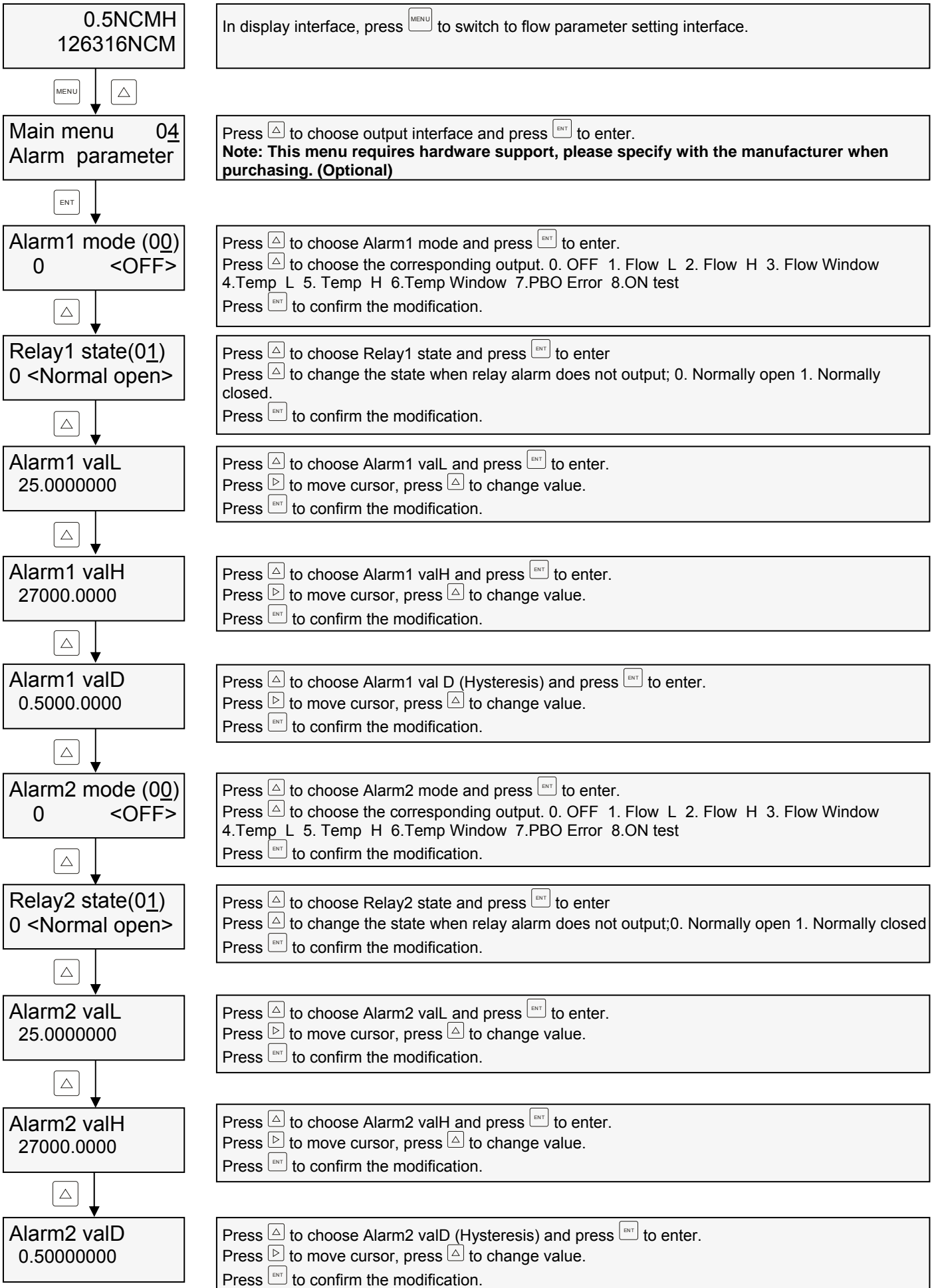
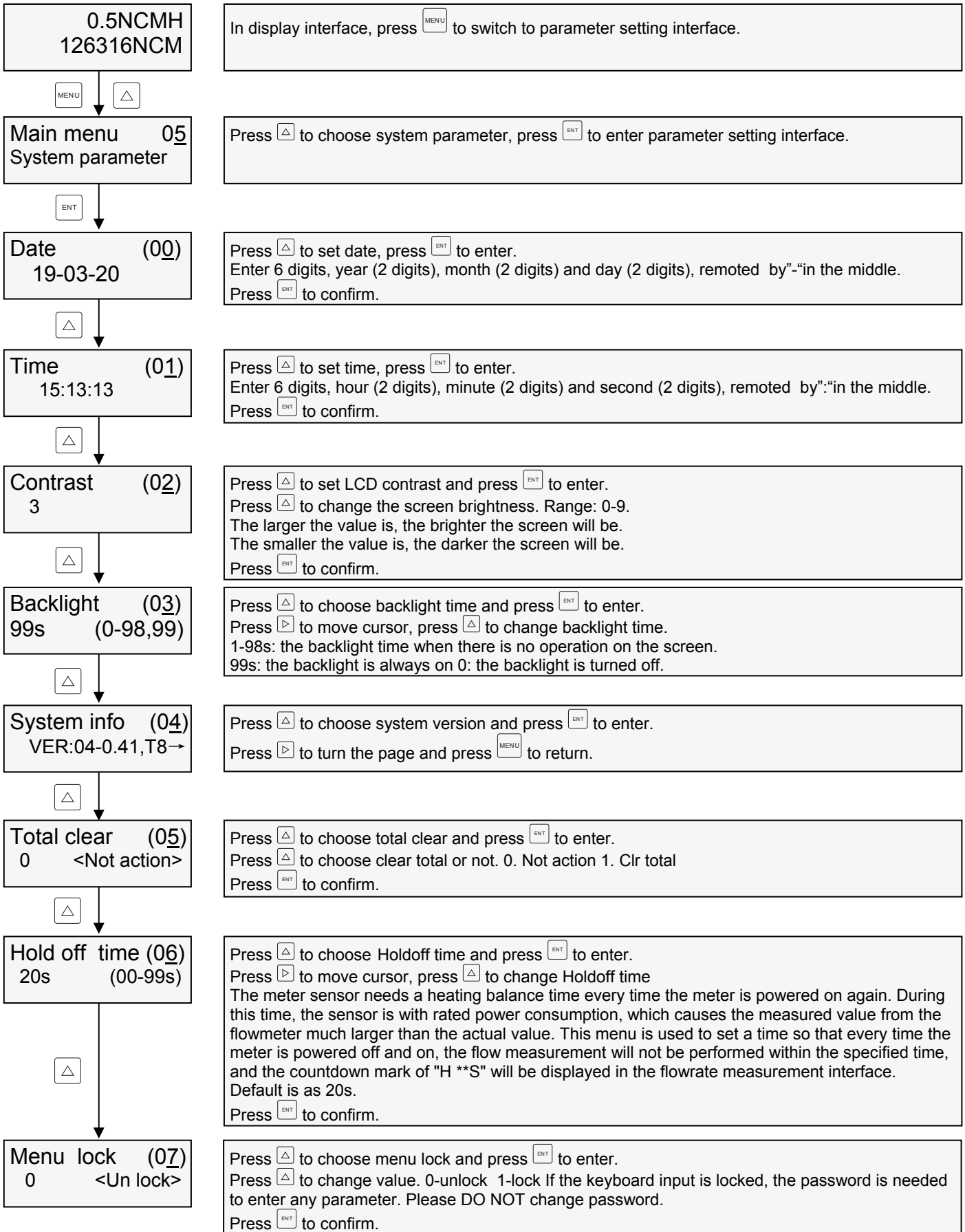

Figure 2

## 6.5 Alarm Parameter Setting



## 6.6 System Parameter Setting



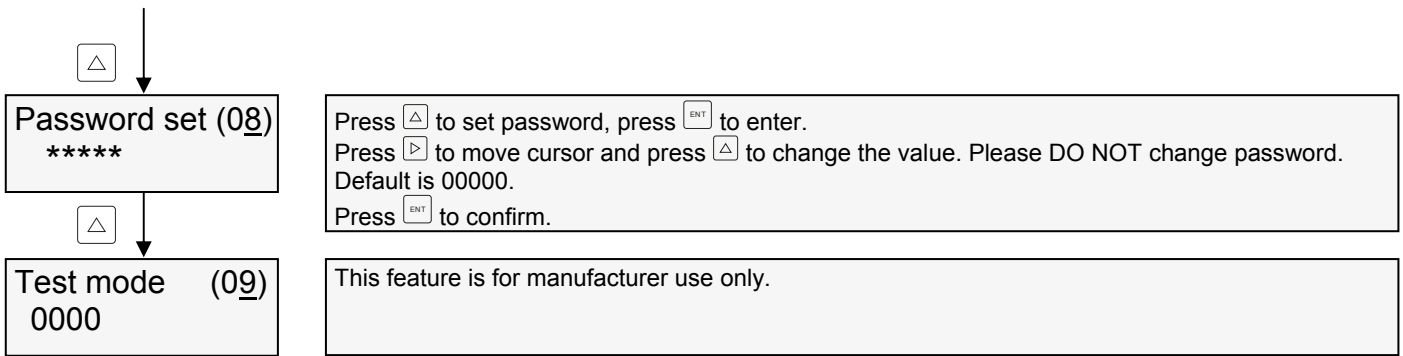

**6.7 Instrument Coefficient**

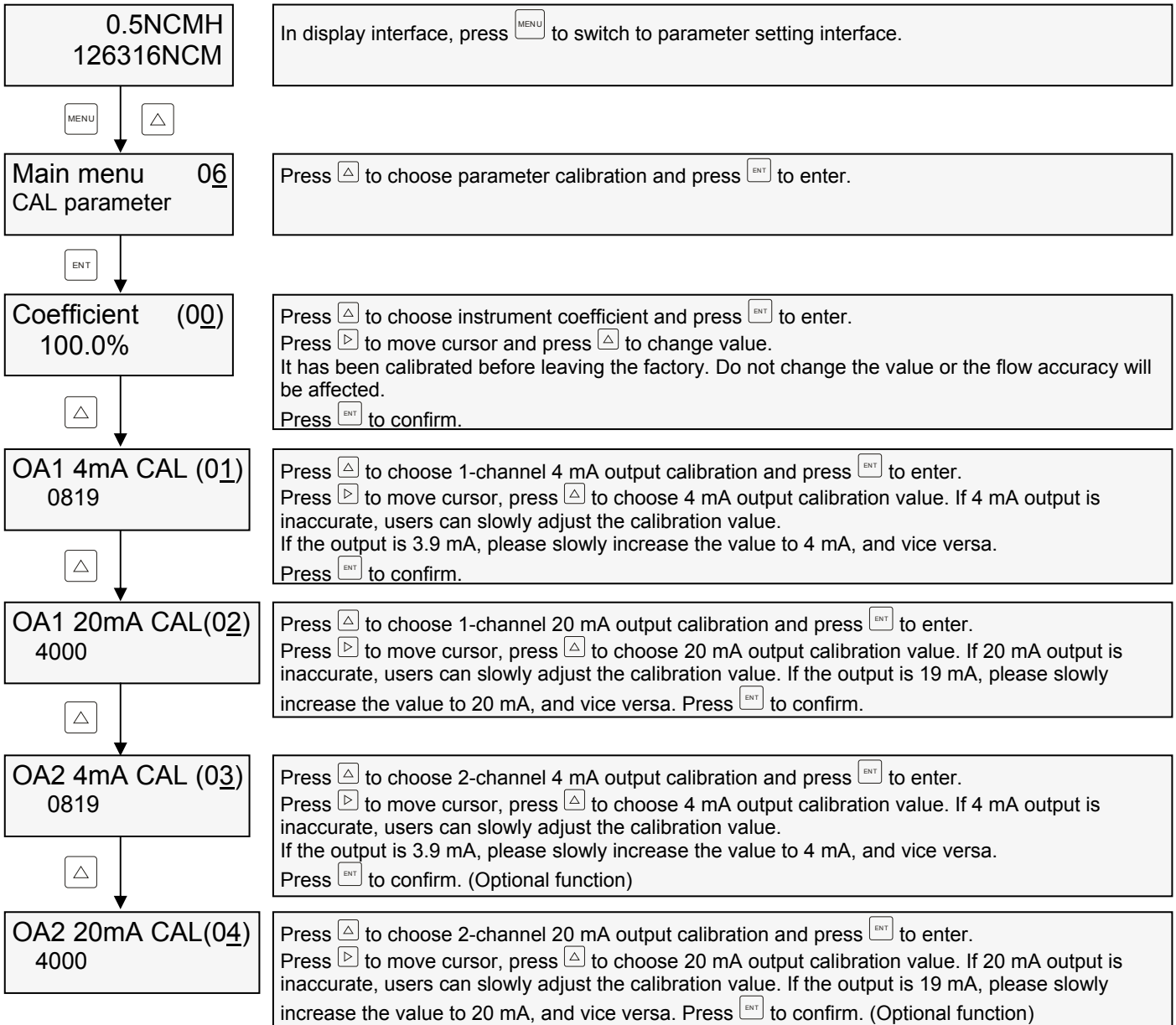



**6.8 View Log**

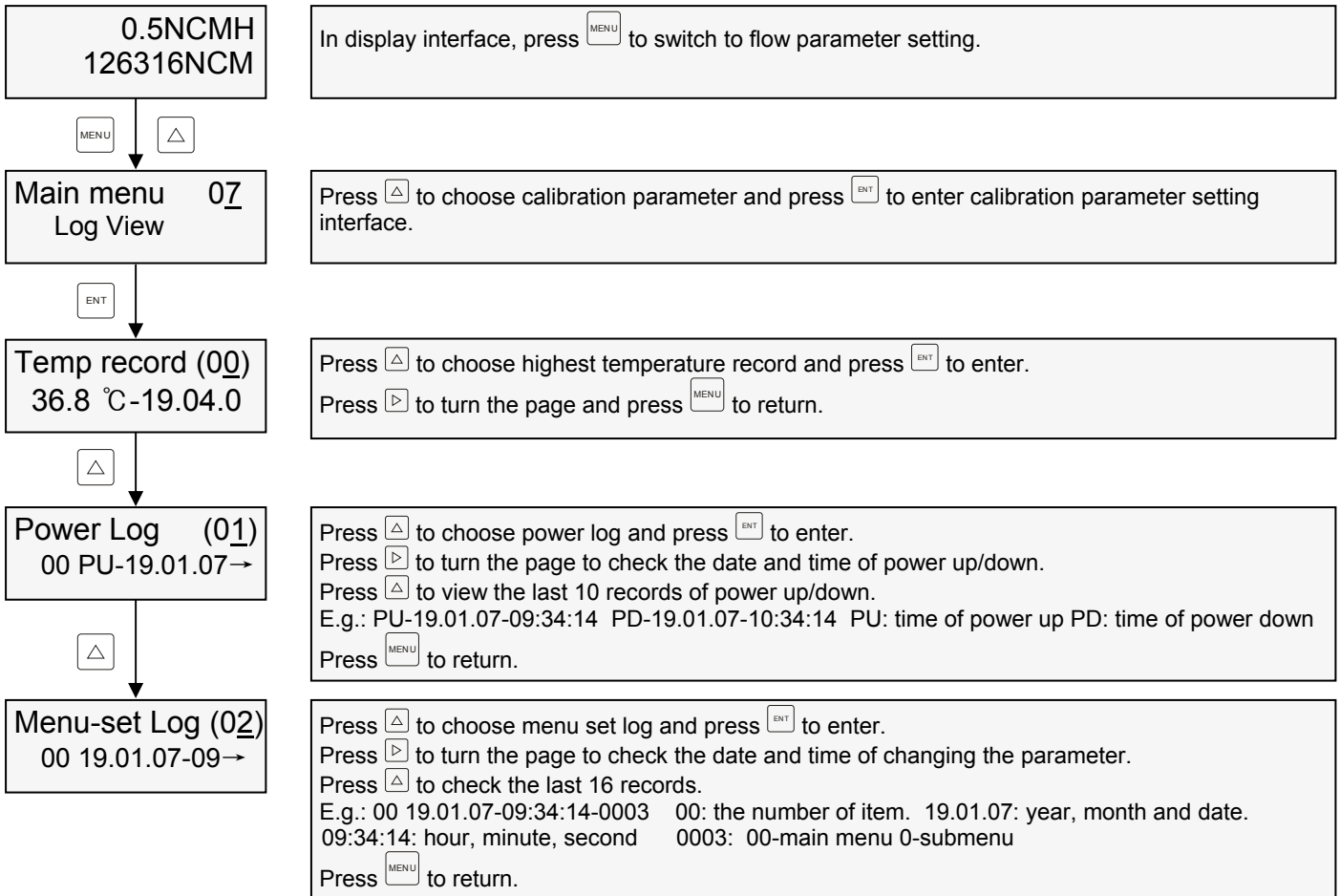

## 7. Maintenance

If the measuring medium is dirty, some dirt may accumulate on the instrument sensor after running for a period of time. Thus the sensor needs to be cleaned and maintained regularly to remove dirt. But if the measurement medium is pure, this step can be omitted.

The plug-in instrument can realize the non-stop production maintenance and operation under the premise of ensuring that the measurement medium and the on-site environment permit the on-line disassembly without stopping production. The disassembly is the reverse of the installation. For Pipe-type instrument, the production should be stopped for disassembly and maintenance.

## 8. Troubleshooting

Trouble	Possible cause	Treatment
No display	A. Power supply B. The fuse of meter is broken	A. Check the supply voltage and polarity B. Measure the voltage at the terminals C. Check if the fuse is broken
Small flow	A. The flow direction indicated on flowmeter is different from which of the actual flow B. The sensor is dirty	A. Adjust the angle of the flowmeter so that the flow direction on the flowmeter is the same as the gas flow direction B. Take out the sensor and clean it
Abnormal flow, great fluctuation	A. The fluid is pulsating B. The sensor is dirty C. The sensor is broken	A. Increase the damping coefficient B. Take out the sensor and clean it C. Return to the manufacturer for maintenance
4-20 mA is abnormal	A. 20 mA The range of 20 mA is set incorrectly B. The wiring does not form a loop. C. Circuit failure	A. Set the range correctly B. Check the wiring C. Return to the manufacturer for maintenance
RS485 is abnormal	A. Baud rate or address is set wrongly B. The polarity is reverse	A. Set them correctly B. Change the polarity

## 9. Noun Interpretation

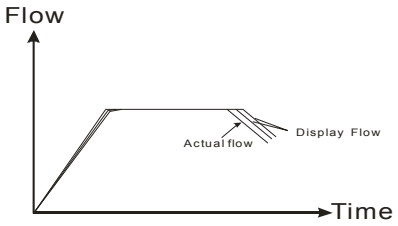
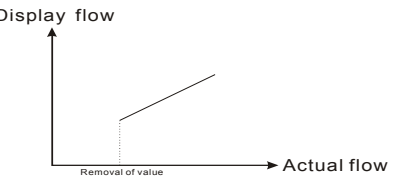
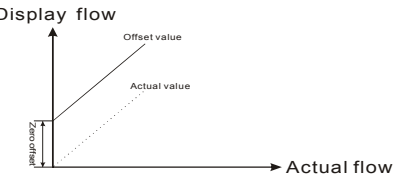
Name	Menu	Illustrate	Factory setting
Damping time	Damping time	<p>Damping time determines the tracking speed of the displayed flow rate to actual flow rate.</p> 	5S
Low cut-off	Low cut-off	<p>It is used to cut off the small flow that users do not want to display and measure accumulative. If the actual flow is lower than this value, the transmitter will show 0 flow rate.</p> 	0.1
Zero cut-off	Zero cut-off	<p>If zero offset occurs in the instrument, it is necessary to adjust the zero and cut off the corresponding zero value.</p> 	0.1
Coefficient	Coefficient	<p>The method to correct the accuracy of instrument is as follows:            Meter coefficient = {Truth value / (Apparent value / original coefficient)} * 100%            E.g.: Truth value = 1 Nm<sup>3</sup>/hr                  Apparent value = 0.8 Nm<sup>3</sup>/hr                  Original coefficient = 100%            Meter coefficient = {1/(0.8/1)} * 100% = 125%            The coefficient is set to 125%</p>	Set the value according to the default coefficient.

**10. MODBUS Address**

MODBUS Table					
NO.	Content	Data Type	Address	Length	Read
1	Flow rate	Float	Ox0101	Ox0002	03
2	Totalizer	Float	Ox0103	Ox0002	03
3	Temperature	Float	Ox0105	Ox0002	03

**Notes:** The unit of flow rate is consistent with which set in the instrument. If a volume unit is set, the unit of flow rate is Nm<sup>3</sup>/hr. If a mass unit is set, the unit of flow rate is kg/hr.

The unit of totalizer is consistent with which set in the instrument. If a volume unit is set, the unit of totalizer is Nm<sup>3</sup>. If a mass unit is set, the unit of totalizer is kg.

Temperature unit is °C.

**Data sending and receiving**

E.g.: Read flow rate

1. The format of the send command:

(MODBUS Address) + (Function Code) + (Address) + (Register Length) + (CRC Check Code)  
 001                    03                    Ox0101                    Ox0002                    Automatic generation

The sent command: 01 03 0101 0002 **9437**

The format of the received command:

(Meter Address) + (Function Code) + (Data Digit) + (Register Data) + (CRC Check Code)  
 01                    03                    04                    3F12                    61BE                    Automatic generation

The received command: 01 03 04 **3F12 61BE FFC2**

**Convert 3F12 61BE in hexadecimal into a floating point value of 0.5 Nm<sup>3</sup>/hr.**