



ALIAMAG

Converter For Electromagnetic Flowmeter

Model AMC40CS Series

GENERAL

ALIAMAG The ALIAMAG AMC40CS Series converter is a microprocessor based intelligent transmitter that can be paired with any of the Alia AMF series sensors. The unit features multiple display parameters including flow rate, flow total, diagnostics, programming and troubleshooting.

FEATURES

- ❑ Battery life 2-3 years in normal working condition
- ❑ Accuracy of +/-0.3% value of reading
- ❑ Bi-directional flow measurement, current and pulse output
- ❑ 3 lines of LCD display flowrate and totalizer
- ❑ Records up to 99 power on / off time
- ❑ IP67 / IP68 protection class

STANDARD SPECIFICATION



- Excitation : DC pulsed
- Display : 3 Lines of LCD
 - Page 1 / Line 1 : 5-Digit flowrate
 - Page 1 / Line 2 : 11-Digit forward totalizer
 - Page 1 / Line 3 : Flow Percentage
 - Page 2 / Line 1 : 11-Digit totalizer
 - Page 2 / Line 2 : 11-Digit reverse totalizer
 - Page 2 / Line 3 : Display instantaneous velocity
 - Page 3 : Alarm
- Flow Unit : m³/hr, m³/min, m³/sec, L/hr, L/min
GPH, GPM, GPS, mL/hr, mL/min, mL/s
- Totalizer Unit : m³, Gallon, Liter, mL
- Measuring Range : Min. 0-0.15 m/s
: Max. 0-15.0 m/s
- Accuracy : +/-0.3% of reading (Velocity ≥ 0.5 m/s)
: +/-0.0015 m/s (Velocity < 0.5 m/s)
- Repeatability : +/-0.05% of reading
- Pulse Output : Open collector
Load : 3-30 VDC, Max. 20 mA
- Pulse Rate : 1) Scaled pulse (Liter / Pulse, other)
: 2) Frequency: 1-5000 Hz
- Keypad : 4 Control keys to change parameters
and switch display interface
- Damping : 0.1-99.9 s
- Data Storage : Operation parameters and totalizer are
stored by EEPROM for more than 10 years
- Low Flow Cutoff : 0-9.9%
- Self Diagnosis : The following error messages
are displayed if failure occurs
 - Coil failure
 - Power failure
 - Overranged output
 - Internal error
 - Overflow
 - Empty pipe
- Cable Entry : Standard: PG11 Option: 1/2" NPTF
- Protection Class : IP67
: IP68 (Submersible)
- Ambient Temp. : -25~65 °C
- Housing Material : Aluminum alloy
- Power Supply : 3.6 V battery, Size D
- Battery Life : 2-3 Years
Determined by size & function
- Communication Protocol : RS485 (MODBUS protocol)
- Weight : 2.0 kg (Compact)
4.3 kg (Remote)
- Mounting : Wall mounting
Bracket on 2" pipe
Compact version (Installed on sensor)



ALIA TECHNOLOGY LLC

633 W. 5th Street, 26th Floor, Los Angeles, CA 90071, USA
TEL : + 1 - 213 - 533 - 4139 FAX : + 1 - 213 - 223 - 2317



URL : www.alia-inc.com
E-mail : alia@alia-inc.com
AMC40CSV1.2.3.A4.en

➤ DIMENSIONS

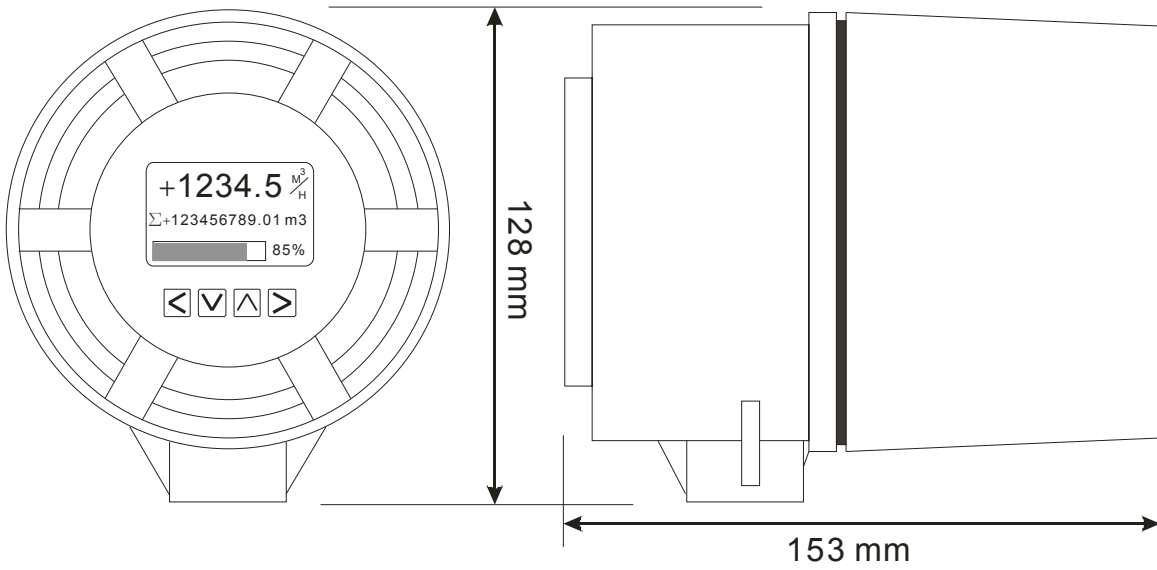

➤ WIRING DIAGRAM

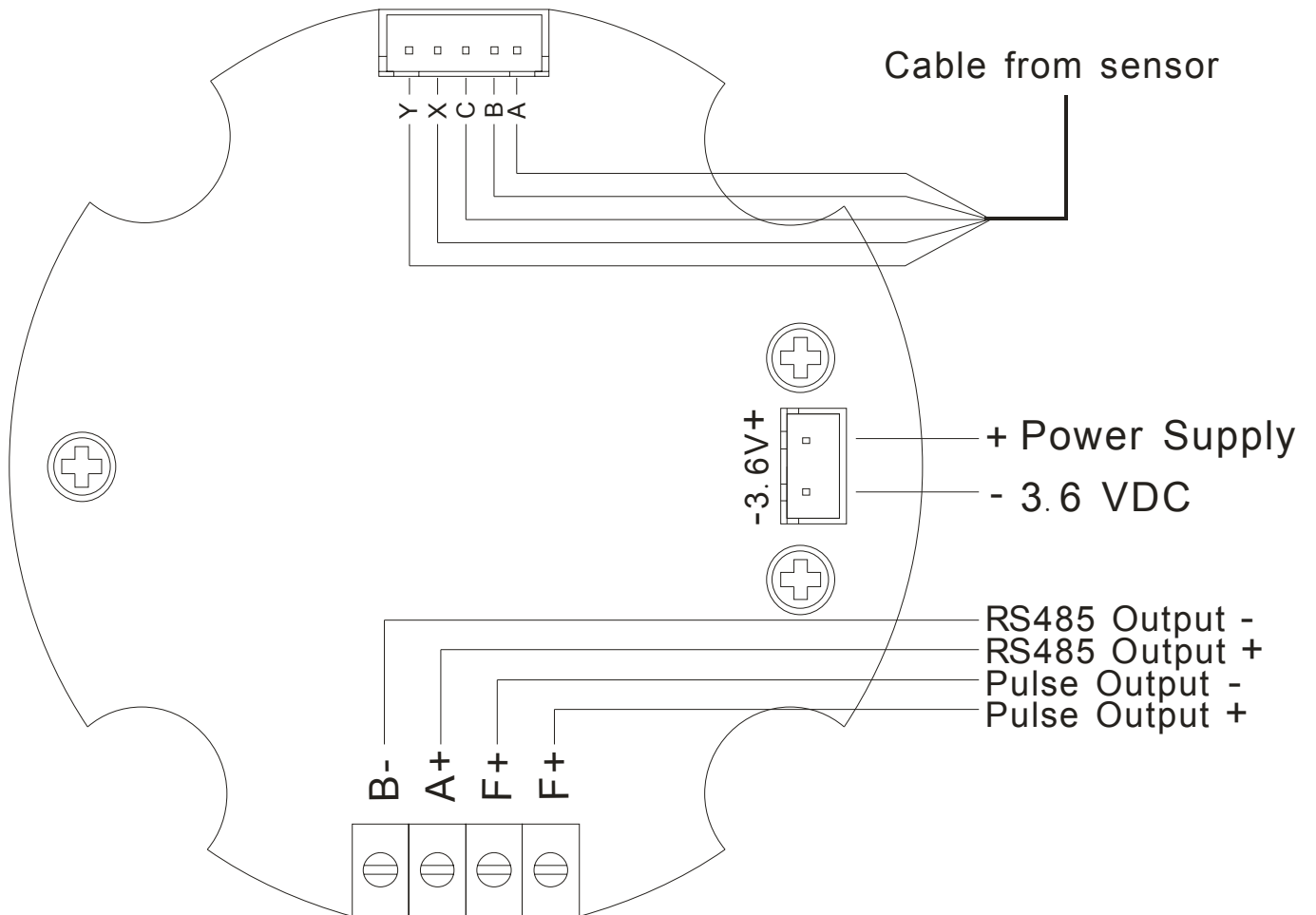

➤ ACCURACY

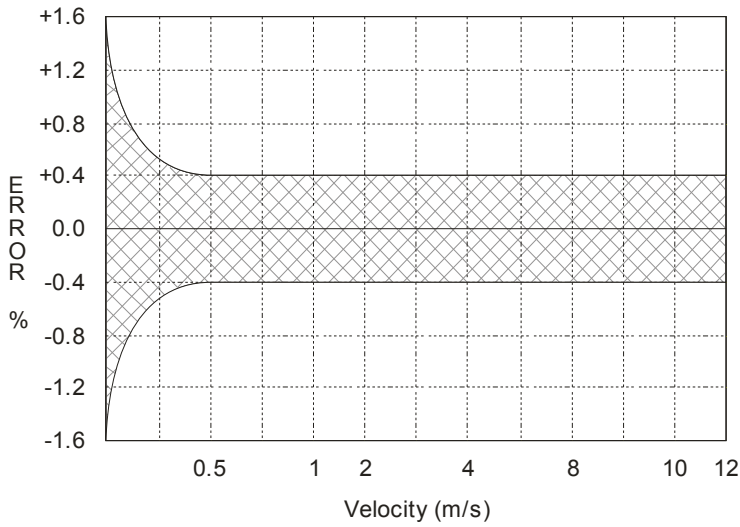

➤ CABLE LENGTH BETWEEN SENSOR & CONVERTER

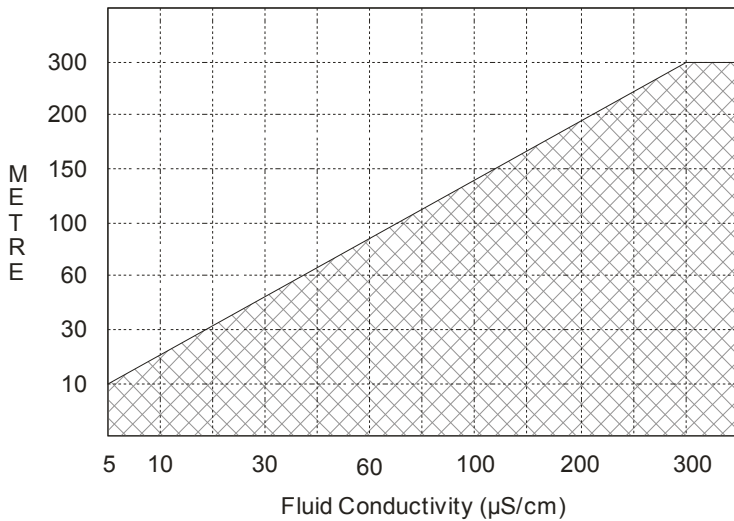

➤ MODEL SELECTION GUIDE

AMC40CS Series					
Example: AMC40CS-CP-NN-BX-NN					
AMC40CS-	XX-	XX-	XX-	XX	Description
Mounting	CP-				Compact with Sensor
	SW-				Remote, Wall Mounting
	S2-				Remote, 2" Mounting Bracket
Protection Class	NN-				IP67
	68-				IP68 (Submersible)
Battery	BX-				Battery Box without Battery
	BT-				Battery Box with Battery, 3.6 V / Size D * 4 Pcs
Cable Entry	NN				None
	EP				6 pin IP65 connector (External Power / Frequency / RS485)
	PT				1/2" NPTF

➤ BUILD OPTIONS-(COMPACT OR REMOTE)

Remote Type



Compact Type